

DO NOT SCALE FROM THIS PRINT

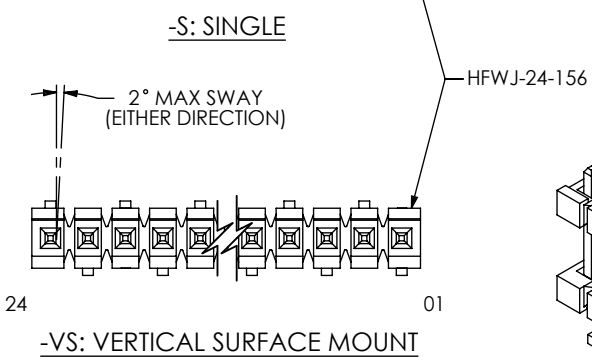

JW-XX-XX-XX-X-XXX-XXX-XX-X

No OF POSITIONS
 -02 THRU -24

LEAD STYLE
 -04: T-1S8-05-X
 -05: T-1S8-05-X

PLATING SPECIFICATION
 -T: TIN (USE T-1S8-05-T)
 -TM: MATTE TIN (USE T-1S8-05-T)

OPTION
 -P: PICK & PLACE PAD (USE PPP-47, SEE FIG. 2, SHEET 2)
 (-VS ONLY, 3 POSITION MIN, .275[6.99] MIN POST HEIGHT)

OPTION
 -VS: VERTICAL SURFACE MOUNT

POST HEIGHT
 -XXX: SPECIFY POST HEIGHT .000 MIN (SEE NOTE 3)

SPACE OPTION
 -XXX: SPECIFY BOARD SPACING

ROW SPECIFICATION
 -S: SINGLE (USE HFWJ-24-156)

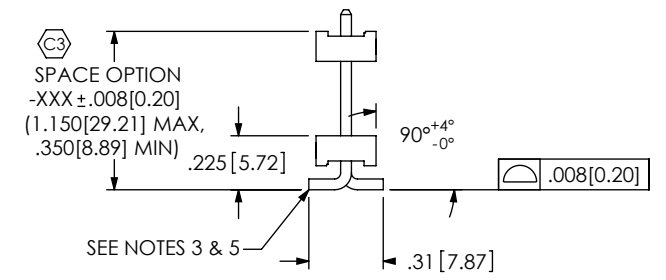
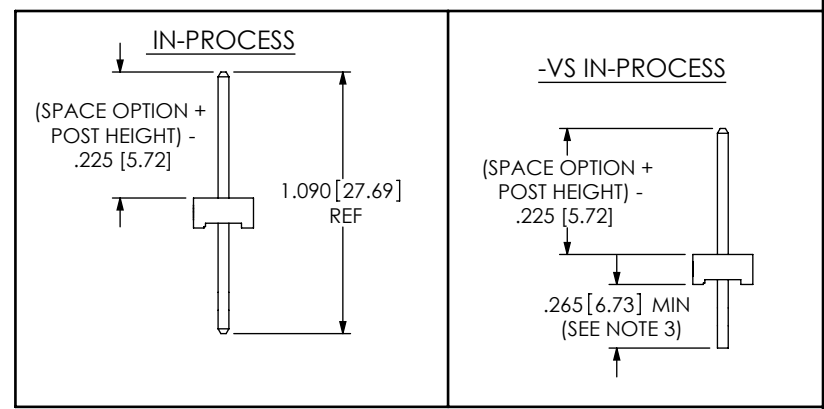
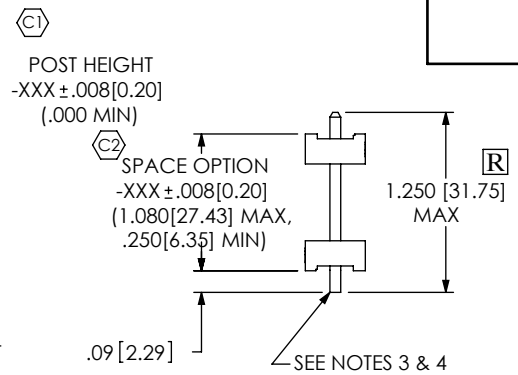
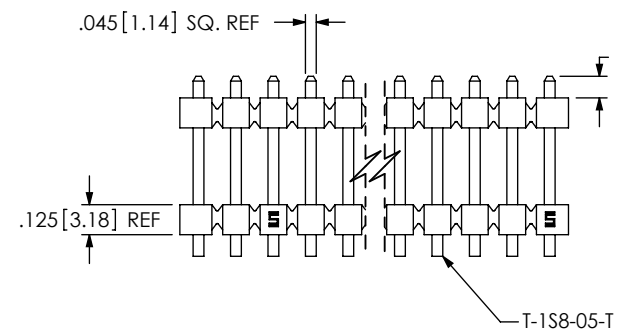

-S: SINGLE

-VS: VERTICAL SURFACE MOUNT

NOTES:

- HEIGHT VARIATION BETWEEN ANY TWO PINS SHALL BE .010[0.25] MAX.
- MAXIMUM PIN ROTATION IN BODY: 2°.
- TAIL TO BE SHEARED TO .265[6.73] MIN. A SECOND SHEAR STEP WILL BE NEEDED AFTER FORMING TO ACHIEVE THE TAIL TO TAIL DIM.
- MAXIMUM BURR ALLOWED: .004[0.10].
- MAXIMUM BURR ALLOWED: .0015[0.038].
- THROUGH HOLE TO BE BULK PACKAGED.
- VERTICAL SURFACE MOUNT (-VS) TO BE PACKAGED AS FOLLOWS:
 POSITIONS -04 THRU -24 ARE TO BE PACKAGED IN TUBES (SEE TABLE 1, SHEET 2);
 POSITIONS -02 AND -03 ARE TO BE LAYER PACKAGED.
- MIN PUSHOUT FORCE TO BE 3 LBS.
- MAX CUT FLASH TO BE .020[0.51].
- Ⓢ REPRESENTS A CRITICAL DIMENSION.

UNLESS OTHERWISE SPECIFIED, DIMENSIONS ARE IN INCHES. TOLERANCES ARE: DECIMALS ANGLES .XX: ±.01 [.3] 2° .XXX: ±.005 [.13] .XXXX: ±.0020 [.051]	PROPRIETARY NOTE THIS DOCUMENT CONTAINS INFORMATION CONFIDENTIAL AND PROPRIETARY TO SAMTEC, INC. AND SHALL NOT BE REPRODUCED OR TRANSFERRED TO OTHER DOCUMENTS OR DISCLOSED TO OTHERS OR USED FOR ANY PURPOSE OTHER THAN THAT WHICH IT WAS OBTAINED WITHOUT THE EXPRESSED WRITTEN CONSENT OF SAMTEC, INC.	520 PARK EAST BLVD, NEW ALBANY, IN 47150 PHONE: 812-944-6733 FAX: 812-948-5047 e-Mail: info@SAMTEC.com code: 55322

FIG. 2

-P: PICK & PLACE PAD OPTION
(-VS ONLY, 3 POS. MIN)

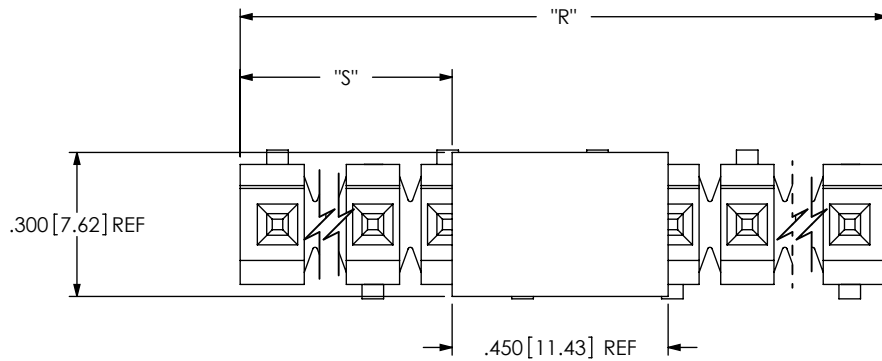

NOTE:

"R" = No OF POS x .156[3.96] REF
 "S" = {("R" - .450[11.43]) / 2} ±.020[12.90]
 "G" = POST HEIGHT (.275[6.99] MIN) + .050[1.27] REF

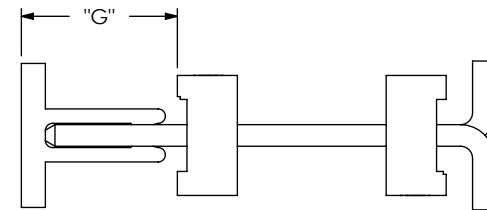

TABLE 1 (SEE NOTE 7)

SPACE OPTION + POST HEIGHT	PACKAGING TUBE	PLUG
.350 TO .725 [8.89 TO 18.42]	PT-1-24-16-29	TP-07
.726 TO .890 [18.44 TO 22.61]	PT-1-24-01-67	TP-13
.891 TO 1.125 [22.61 TO 28.58]	PT-HPW001-P	TP-26

S

PROPRIETARY NOTE

THIS DOCUMENT CONTAINS INFORMATION CONFIDENTIAL AND PROPRIETARY TO SAMTEC, INC. AND SHALL NOT BE REPRODUCED OR TRANSFERRED TO OTHER DOCUMENTS OR DISCLOSED TO OTHERS OR USED FOR ANY PURPOSE OTHER THAN THAT WHICH IT WAS OBTAINED WITHOUT THE EXPRESSED WRITTEN CONSENT OF SAMTEC, INC.

DO NOT SCALE DRAWING

SHEET SCALE: 2.5:1

samtec

520 PARK EAST BLVD, NEW ALBANY, IN 47150
 PHONE: 812-944-6733 FAX: 812-948-5047
 e-Mail: info@SAMTEC.com code: 55322

DESCRIPTION:
 .156[3.96] POWER STACKER ASSEMBLY

DWG. NO.
 JW-XX-XX-XX-X-XXX-XXX-XX-X

BY: KEVIN B 06/12/2002 SHEET 2 OF 2